



WEIDER[®] PRO 455

Model No. WEBE13100

Serial No. _____

Write the serial number in the space above for future reference.

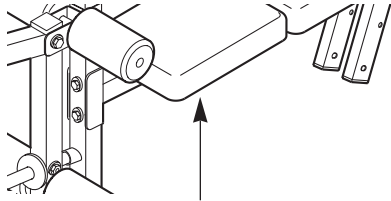

Serial Number Decal (Under Seat)

QUESTIONS?

As a manufacturer, we are committed to providing complete customer satisfaction. If you have questions, or if there are missing parts, we will guarantee complete satisfaction through direct assistance from our factory.

TO AVOID UNNECESSARY DELAYS, PLEASE CALL DIRECT TO OUR TOLL-FREE CUSTOMER HOT LINE. The trained technicians on our customer hot line will provide immediate assistance, free of charge to you.

CUSTOMER HOT LINE:
1-800-999-3756
Mon.-Fri., 6 a.m.-6 p.m. MST

CAUTION

Read all precautions and instructions in this manual before using this equipment. Save this manual for future reference.

USER'S MANUAL

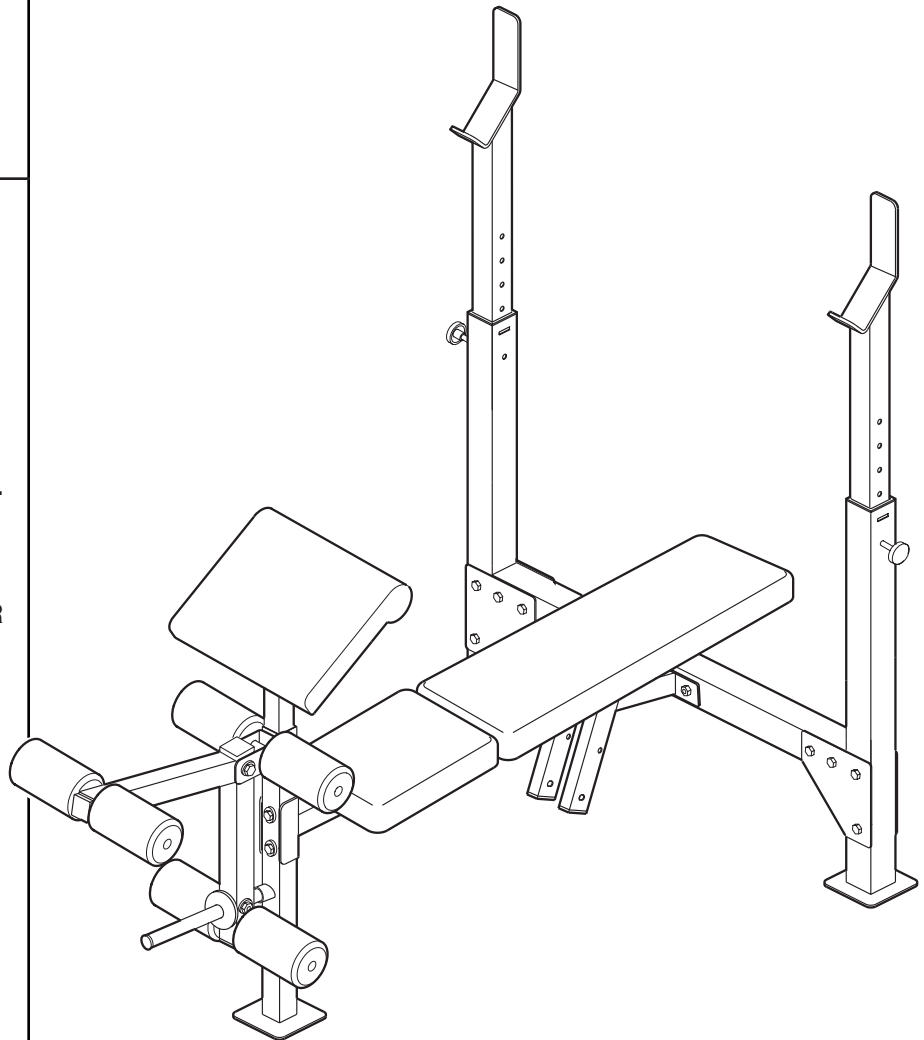

Visit our website at

www.weiderfitness.com

new products, prizes,
fitness tips, and much more!

Table of Contents

WARNING DECAL PLACEMENT	2
IMPORTANT PRECAUTIONS	3
BEFORE YOU BEGIN	4
PART IDENTIFICATION CHART	5
ASSEMBLY	6
USING THE WEIGHT BENCH	9
EXERCISE GUIDELINES	11
PART LIST	14
EXPLODED DRAWING	15
ORDERING REPLACEMENT PARTS	Back Cover
LIMITED WARRANTY	Back Cover

Warning Decal Placement

The decal shown at the right has been placed on the weight bench. If the decal is missing, or if it is not legible, please call our Customer Service Department toll-free at 1-800-999-3756, Monday through Friday, 6 a.m. until 6 p.m. Mountain Time, to order a free replacement decal. Apply the replacement decal in the location shown.

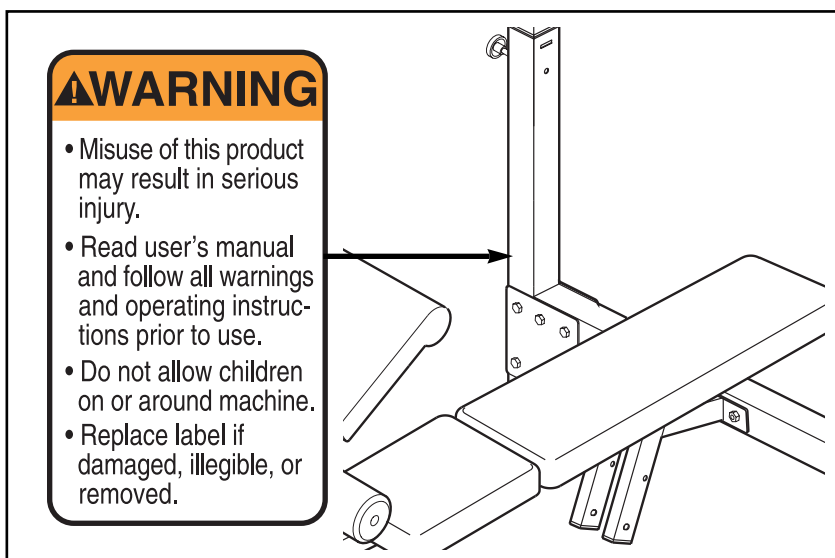

Important Precautions

⚠️ WARNING: To reduce the risk of serious injury, read the following important precautions before using the weight bench.

1. Read all instructions in this manual before using the weight bench.
2. The weight bench is intended for home use only. Do not use the weight bench in any commercial, rental, or institutional setting.
3. It is the responsibility of the owner to ensure that all users of the weight bench are adequately informed of all precautions.
4. Use the weight bench only as described in this manual.
5. Use the weight bench only on a level surface. Cover the floor beneath the weight bench to protect the floor.
6. Inspect and tighten all parts each time you use the weight bench. Replace any worn parts immediately.
7. Keep children under the age of 12 and pets away from the weight bench at all times.
8. Always keep an equal amount of weight on each end of your barbell (not included) when you are using it. When adding or removing weights, always keep some weight on both ends of the barbell to prevent the barbell from tipping.
9. Do not use a barbell that is longer than six feet with the weight bench.
10. When you are using the leg lever, place a barbell with the same amount of weight on the weight rests to balance the bench.
11. Keep hands and feet away from moving parts.
12. Always wear athletic shoes for foot protection while exercising.
13. The weight bench does not include weights. The weight bench is designed to support a maximum of 460 pounds, including the user, a weight bar, and weights. Do not place more than 210 pounds, including a weight bar and weights, on the weight rests. Do not place more than 130 pounds on the leg lever.
14. Make sure that the adjustment knobs are inserted completely and tightened into the uprights before beginning any exercise.
15. When adjusting the position of the backrest, make sure that the adjustment pin is inserted through both adjustment tubes and that the pin clip is attached (see page 10).
16. If you feel pain or dizziness at any time while exercising, stop immediately and begin cooling down.
17. Always remove the curl post from the front leg before performing leg curls with the leg lever.
18. Always exercise with a partner. When you are performing bench press exercises, your partner should stand behind you to catch the barbell if you cannot complete a repetition.
19. When you put weight on the weight rests, make sure you put at least ten pounds on the leg lever to balance the weight bench.

⚠️ WARNING: Before beginning this or any exercise program, consult your physician. This is especially important for persons over the age of 35 or persons with pre-existing health problems. Read all instructions before using. ICON assumes no responsibility for personal injury or property damage sustained by or through the use of this product.

Before You Begin

Thank you for selecting the WEIDER® PRO 455 weight bench. The versatile WEIDER® PRO 455 weight bench is designed to be used with your own weight set (not included) to develop every major muscle group of the body. Whether your goal is a shapely figure, dramatic increase in muscle size and strength, or a healthier cardiovascular system, the WEIDER® PRO 455 will help you to achieve the specific results you want.

For your benefit, read this manual carefully before using the WEIDER® PRO 455 weight bench. If you have additional questions, please call our Customer

Service Department toll-free at 1-800-999-3756, Monday through Friday, 6 a.m. until 6 p.m. Mountain Time (excluding holidays). To help us assist you, please note the product model number and serial number before calling. The model number is WEBE13100. The serial number can be found on a decal attached to the weight bench (see the front cover of this manual).

Before reading further, please look at the drawing below and familiarize yourself with the parts that are labeled.

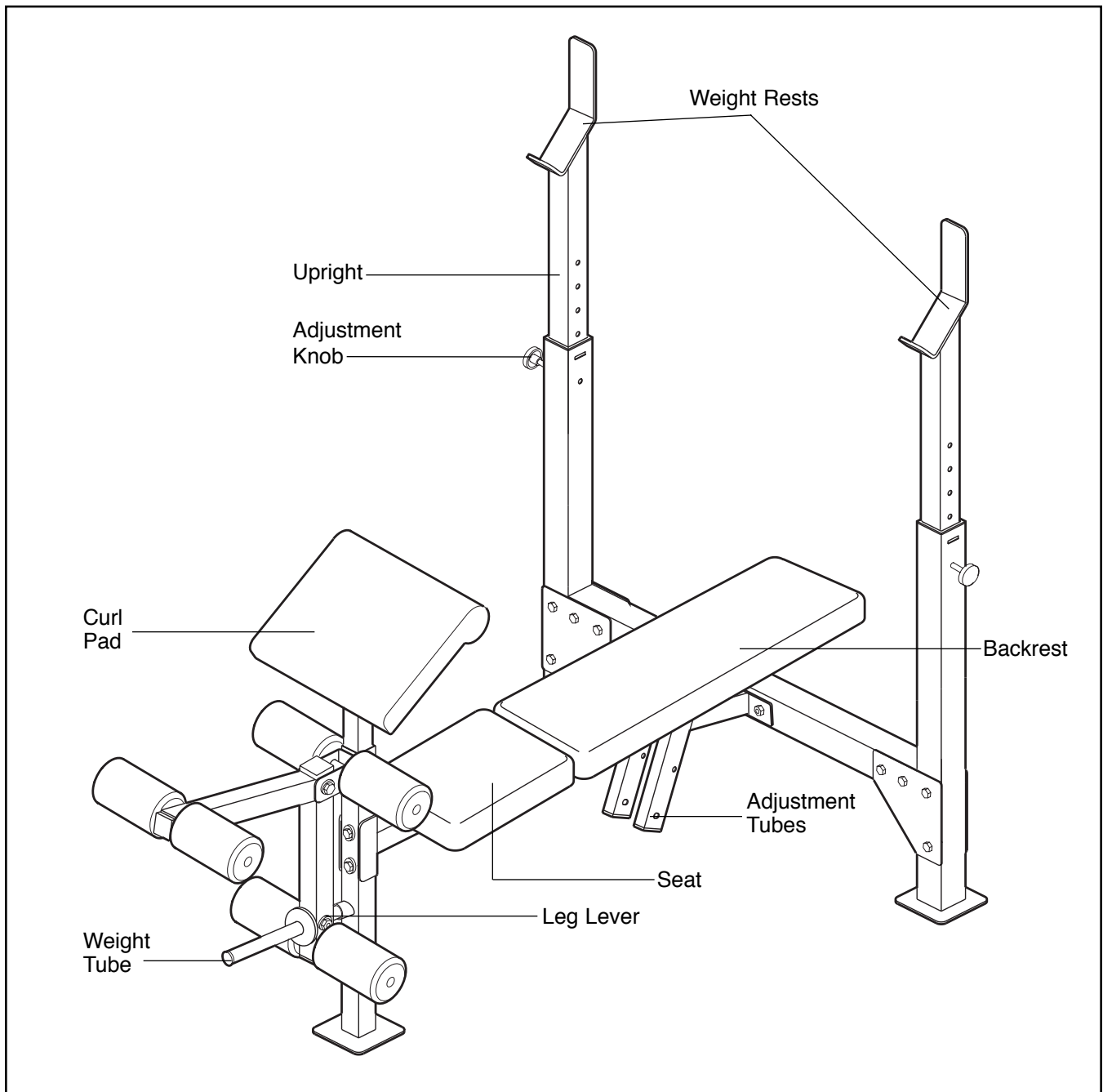

Part Identification Chart

This chart is provided to help you identify the small parts used in assembly. The number in parentheses below each part refers to the key number of the part. The second number refers to the quantity needed for assembly. **Important: Some parts may have been pre-assembled for shipping purposes. If you cannot find a part in the parts bags, check to see if it has been pre-assembled.**

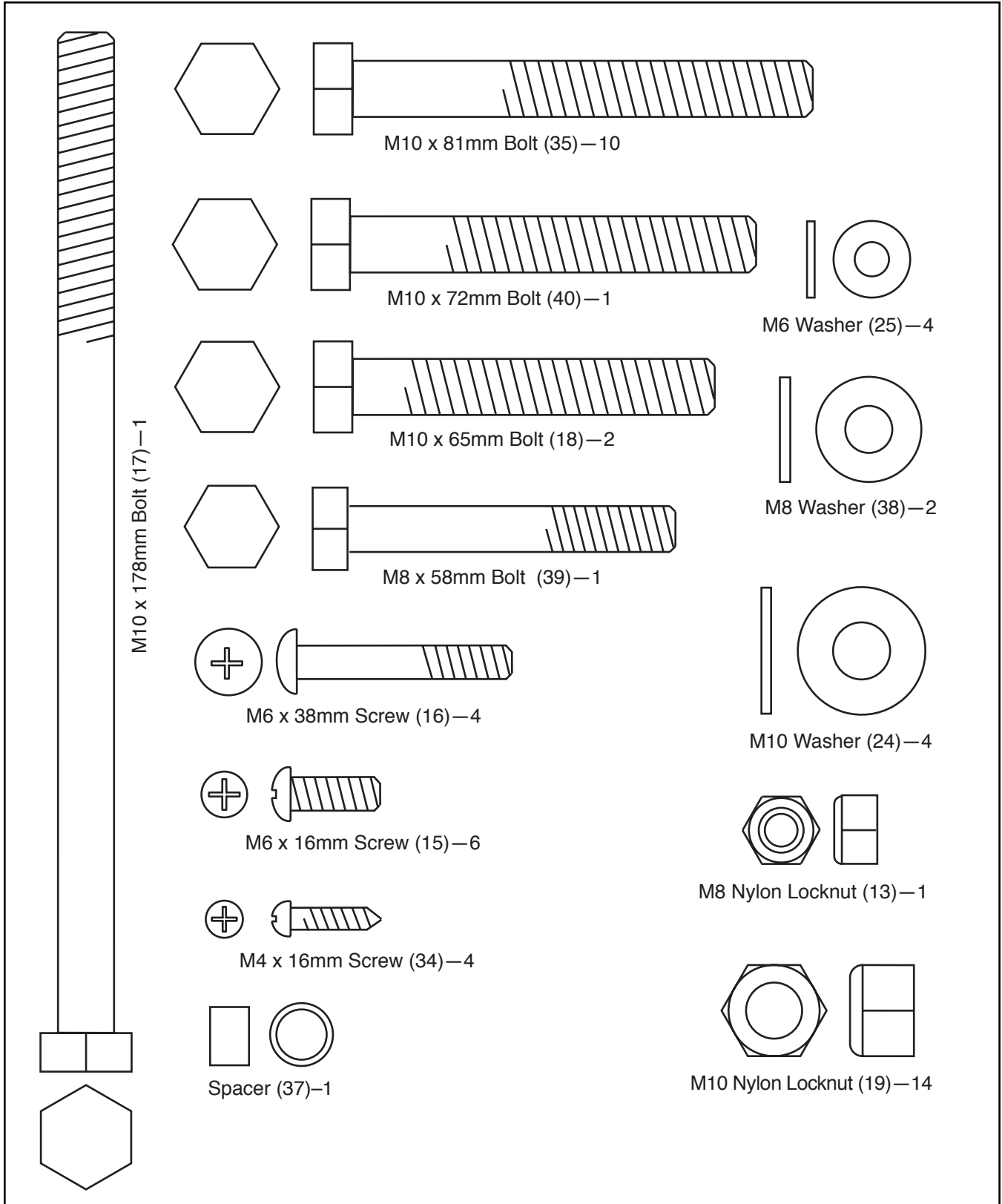



Assembly

Before beginning assembly, carefully read the following information and instructions:

- Place all parts of the weight bench in a cleared area and remove the packing materials; do not dispose of the packing materials until assembly is completed.
- Read each assembly step before you begin.
- For help identifying the small parts used in assembly, **use the PART IDENTIFICATION CHART on the previous page.** Note: Some small parts may have been pre-attached for shipping purposes. If a part is not in the parts bag, check to see if it has been pre-attached.
- Tighten all parts as you assemble them, unless instructed to do otherwise.

- As you assemble the weight bench, make sure that all parts are oriented as shown in the drawings.

THE FOLLOWING TOOLS (NOT INCLUDED) ARE REQUIRED FOR ASSEMBLY:

- **Two (2) adjustable wrenches** 
- **One (1) phillips screwdriver** 
- **One (1) rubber mallet** 
- **Lubricant, such as grease or petroleum jelly, and soapy water will also be needed.**

Assembly will be more convenient if you have the following tools: A socket set, a set of open-end or closed-end wrenches, or a set of ratchet wrenches.

1. **Before assembling this weight bench, be sure that you have read and understand the information in the box above.**

Position the Crossbar (3) as shown. Attach the Crossbar to each Upright Base (7) with four M10 x 81mm Bolts (35), a Support Plate (20), and four M10 Nylon Locknuts (19). **Note the position of the warning decal and make sure the Upright Bases are oriented exactly as shown.**

Slide the Uprights (1) into the Upright Bases (7) and secure them at the desired height with two M10 x 67mm Adjustment Knobs (30).

2. Attach the Frame (2) to the Crossbar (3) with two M10 x 81mm Bolts (35), the "U" Bracket, (14) and two M10 Nylon Locknuts (19). Make sure the "U" Bracket is oriented exactly as shown. **Note: the Frame (2) must be seated firmly against the Crossbar (3) so that the "U" Bracket can fit over both of them.**

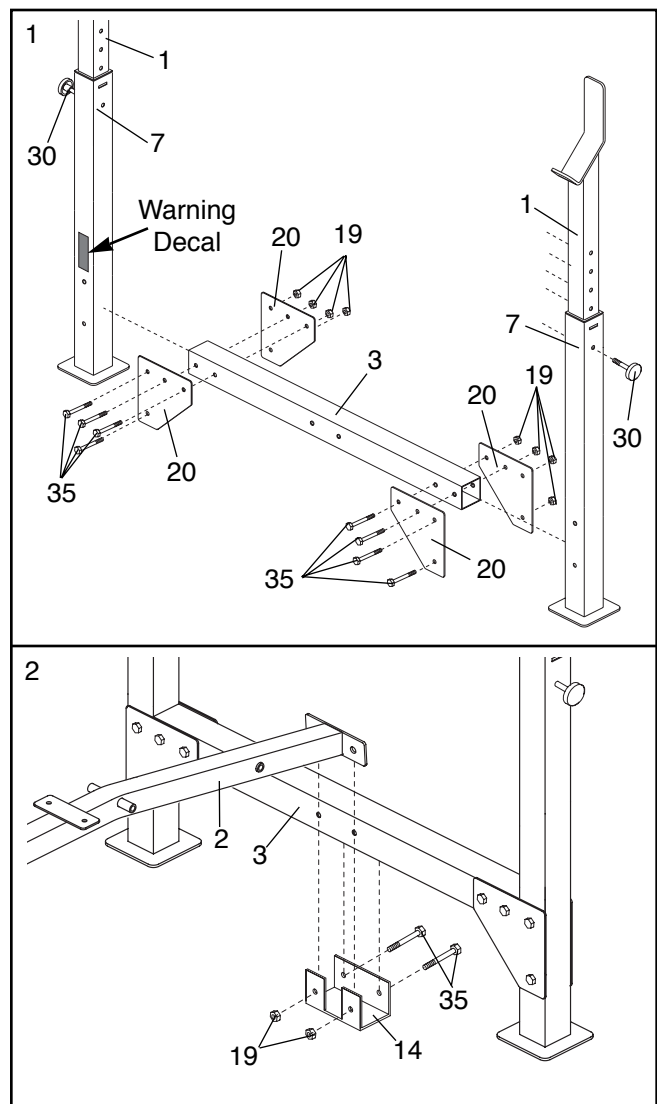

- Attach the Front Leg (8) to the Frame (2) with two M10 x 65mm Bolts (18), two M10 Washers (24), and two M10 Nylon Locknuts (19).

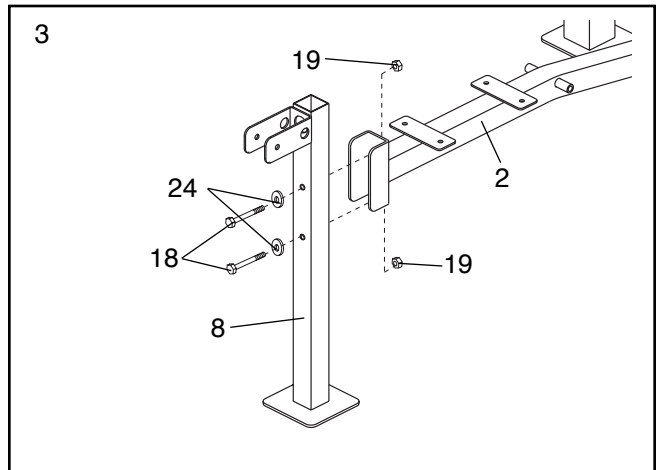

- Tap three 45mm Square Inner Caps (21) into the Leg Lever (4) as shown.

Tap a 1" Round Inner Cap (23) into the indicated end of the Weight Tube (41).

Insert the Weight Tube (41) into the Leg Lever (4). Press a 1" Angle Cap (29) onto the indicated end of the Weight Tube.

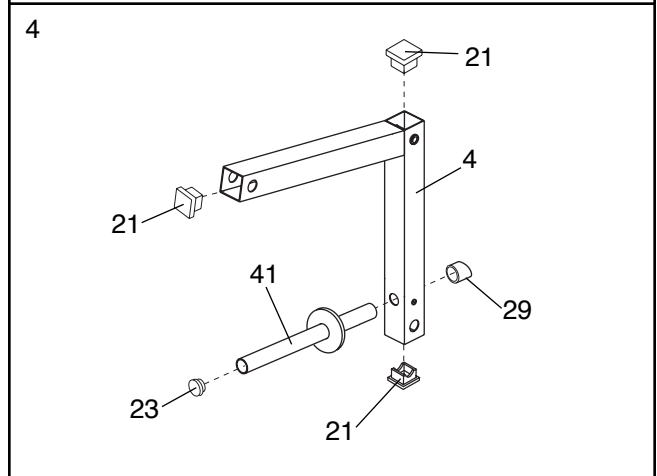

- Lubricate an M10 x 72mm Bolt (40). Attach the Leg Lever (4) to the Front Leg (8) with the Bolt and an M10 Nylon Locknut (19). **Do not overtighten the Nylon Locknut. The Leg Lever must be able to pivot freely.**

Attach the Spacer (37) to the Leg Lever (4) with the M8 x 58mm Bolt (39), two M8 Washers (38), and an M8 Nylon Locknut (13). **Note: The Spacer will fit tightly inside the Leg Lever.**

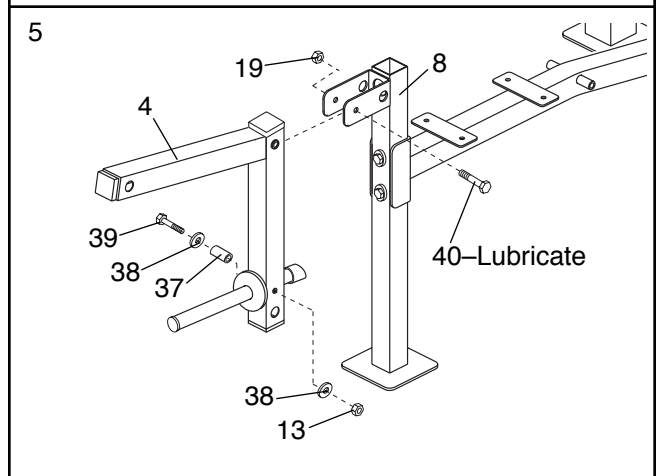

- Press four 1" Square Inner Caps (12) into the Backrest Tubes (5, 42). Press two 1" x 2" Inner Caps (36) into the adjustment tubes.

With the wide end of the Backrest (6) positioned as shown, attach the Backrest Tubes (5, 42) to the Backrest with four M6 x 38mm Screws (16) and four M6 Washers (25). **Note: The Backrest Tubes and the Backrest must be oriented exactly as shown.**

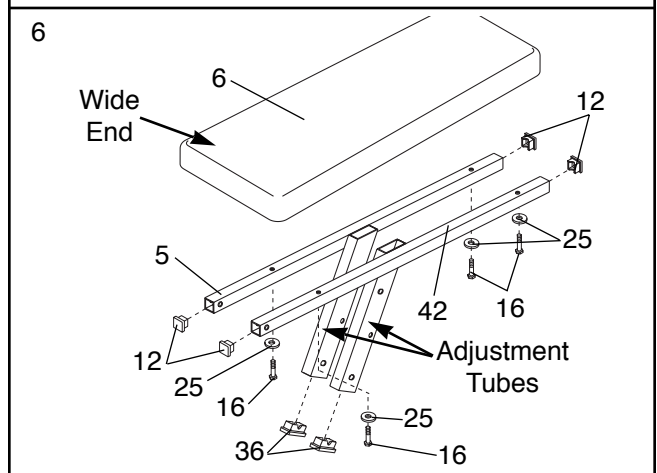

- Lubricate the M10 x 178mm Bolt (17). Attach the Backrest Tubes (5, 42) to the Frame (2) with the Bolt, two M10 Washers (24), and an M10 Nylon Locknut (19).

Secure the Backrest (6) to the Frame (2) by inserting the Adjustment Pin (32) through one of the three sets of holes in the adjustment tubes. Secure the Adjustment Pin with the Pin Clip (43).

Make sure the Adjustment Pin (32) is completely inserted through both adjustment tubes.

- With the wide end of the Seat (11) positioned as shown, attach the Seat to the brackets on the Frame (2) with four M6 x 16mm Screws (15).

- Attach the Curl Pad (27) to the Curl Post (26) with two M6 x 16mm Screws (15).

- Slide the Curl Post (26) into the Front Leg (8). Align one of the adjustment holes in the Curl Post with the adjustment hole in the Front Leg. Fully tighten the M10 x 48mm Adjustment Knob (33) into the adjustment hole in the Front Leg.

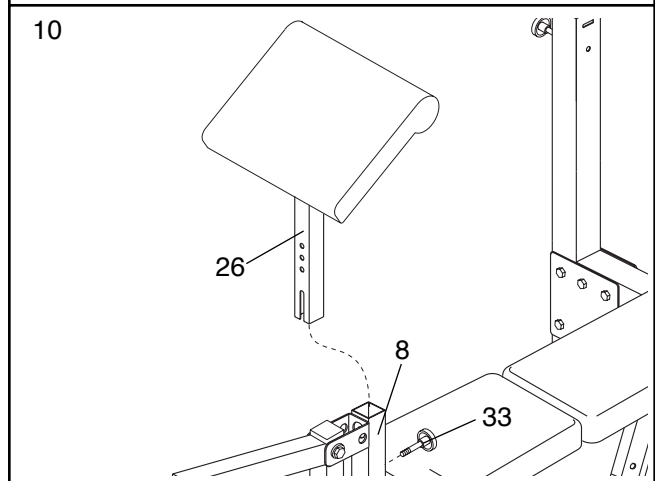
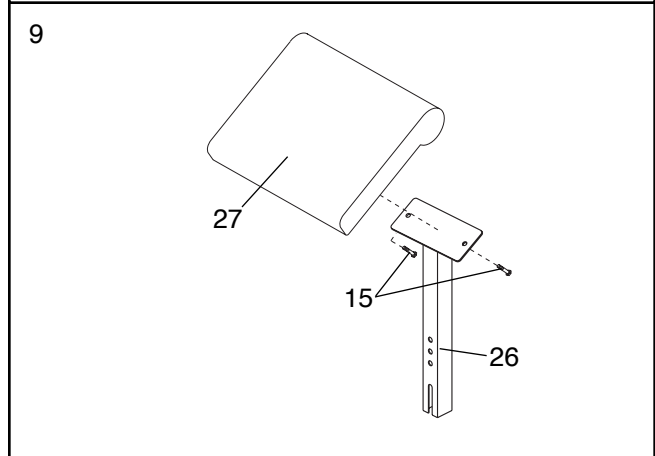
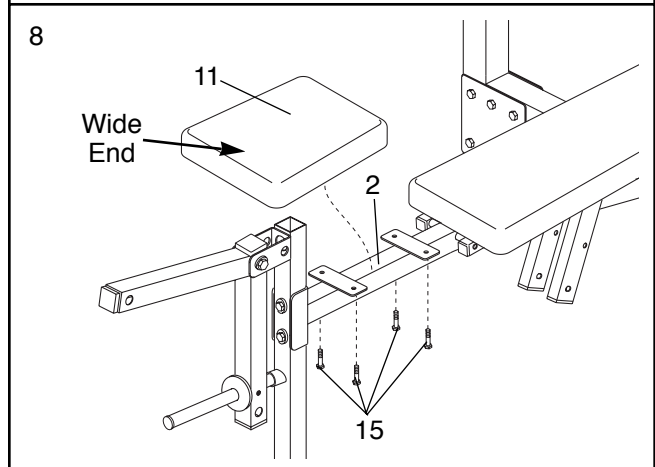
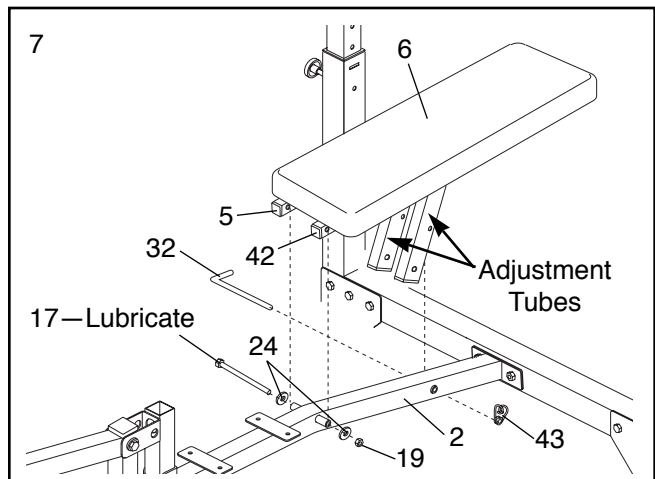

11. Tap two 3/4" Round Inner Caps (9) into each Pad Tube (10). Insert the Pad Tubes into the holes in the Leg Lever (4) and the Front Leg (8). Slide two Foam Pads (22) onto each Pad Tube.

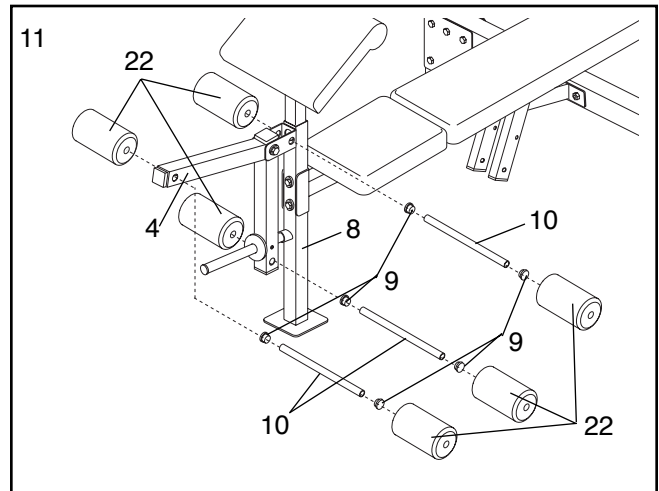

12. **Make sure that all parts are properly tightened before you use the weight bench.** The use of all remaining parts will be explained in USING THE WEIGHT BENCH on pages 9 and 10.

Using the Weight Bench

The weight bench is designed to be used with your own weight set (not included). The steps below explain how the weight bench can be adjusted. See EXERCISE GUIDELINES on page 11 for important exercise information and refer to the accompanying exercise poster to see the correct form for several exercises. Refer also to the exercise information accompanying your weight set (not included) for additional exercises.

Inspect and tighten all parts each time you use the weight bench. Replace any worn parts immediately. The weight bench can be cleaned with a damp cloth and a mild, non-abrasive detergent. Do not use solvents.

ATTACHING WEIGHTS TO THE LEG LEVER

To use the Leg Lever (4), slide the desired weights (not included) onto the Weight Tube (41).

⚠ WARNING: Do not place more than 130 pounds on the leg lever.

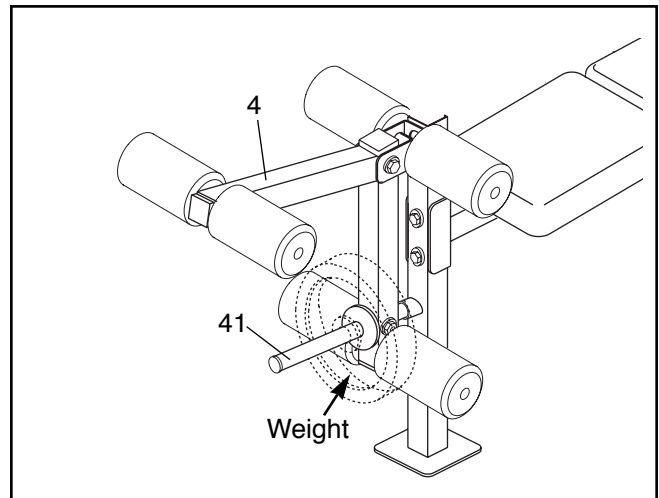

REMOVING THE PAD TUBE AND PADS

To do leg curl exercises, the indicated Pad Tube (10) and Pads (22) must be removed from the weight bench. To do this, slide one of the Pads off the Tube, then pull the Tube out of the holes.

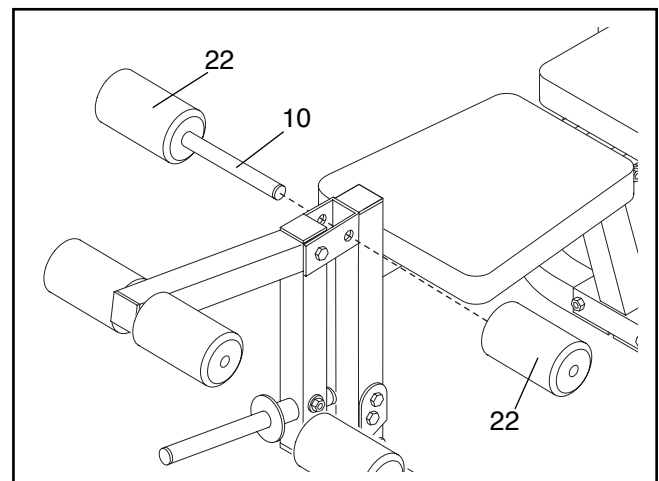

ATTACHING THE CURL POST

For some exercises, the Curl Post (26) must be attached to the weight bench.

Slide the Curl Post (26) into the Front Leg (8). Align one of the adjustment holes in the Curl Post with the adjustment hole in the Front Leg. Fully tighten the M10 x 54mm Adjustment Knob (33) into the adjustment hole in the Front Leg.

Note: When the Curl Post (26) is not in use, the 45mm Square Inner Cap (21) should be inserted into the Front Leg (8).

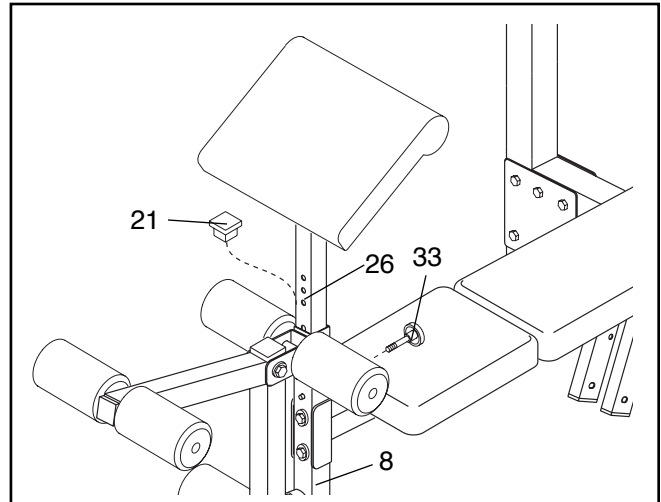

ADJUSTING THE UPRIGHTS

The Uprights (1) can be adjusted to five heights for different exercises. To adjust the height, remove the M10 x 67mm Adjustment Knobs (30) from both Uprights and Upright Bases (7). Slide the Uprights to the desired position and re-insert the Adjustment Knobs.

⚠ WARNING: Always set both uprights at the same height. Make sure that the adjustment knobs are inserted completely and tightened into the uprights.

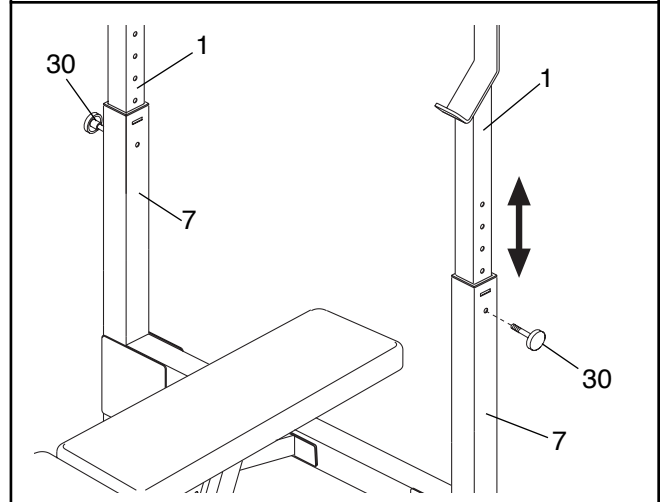

ADJUSTING THE BACKREST

The Backrest (6) can be used in a decline position, a level position, or either of two incline positions. To adjust the Backrest to the decline position, remove the Adjustment Pin (32) and lower the Backrest until it rests directly on the Crossbar (3). Re-insert the Adjustment Pin and secure it with the Pin Clip (43).

To adjust the Backrest (6) to the level position, insert the Adjustment Pin (32) through the top set of holes, and secure it with the Pin Clip (43).

To adjust the Backrest (6) to an incline position, insert the Adjustment Pin (32) as shown through one of the lower two sets of holes in the backrest adjustment tubes. Secure the Adjustment Pin with the Pin Clip (43).

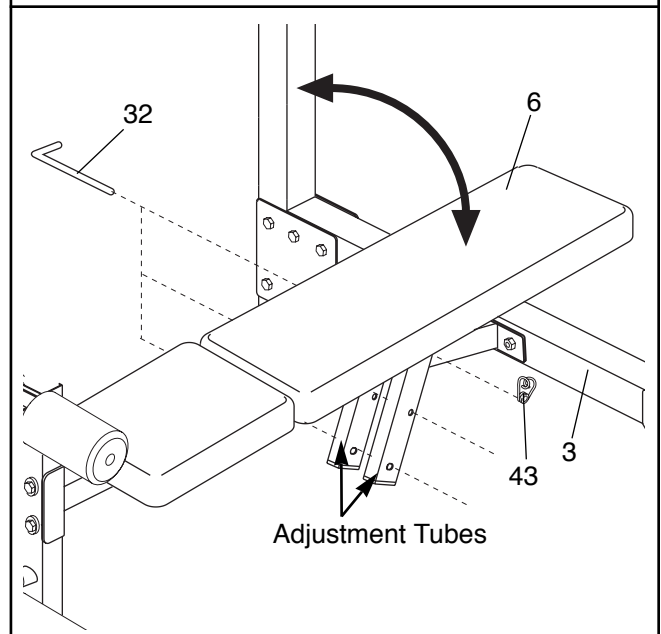

⚠ WARNING: When adjusting the position of the backrest, make sure that the adjustment pin is inserted through both adjustment tubes.

Exercise Guidelines

THE FOUR BASIC TYPES OF WORKOUTS

• Muscle Building

In order to increase the size and strength of your muscles, you must push your muscles to a high percentage of their capacity. You must also progressively increase the intensity of your exercise so that your muscles will continually adapt and grow. Each individual exercise can be tailored to the proper intensity level by changing the amount of weight used, or the number of repetitions or sets performed. (A “repetition” is one complete cycle of an exercise, such as one sit-up. A “set” is a series of repetitions performed consecutively.)

The proper amount of weight for each exercise depends upon the individual user. It is up to you to gauge your limits. Select the amount of weight that you think is right for you. Begin with 3 sets of 8 repetitions for each exercise that you perform. Rest for 3 minutes after each set. When you can complete 3 sets of 12 repetitions without difficulty, increase the amount of weight.

• Toning

To tone your muscles, you must push your muscles to a moderate percentage of their capacity. Select a moderate amount of weight and increase the number of repetitions in each set. Complete as many sets of 15 to 20 repetitions as possible without discomfort. Rest for 1 minute after each set. Work your muscles by completing more sets rather than by using high amounts of weight.

• Weight Loss

To lose weight, use a low amount of weight and increase the number of repetitions in each set. Exercise for 20 to 30 minutes, resting for a maximum of 30 seconds between sets.

• Cross Training

In the pursuit of a complete and well-balanced fitness program, many have found that cross training is the answer. We recommend that on Monday, Wednesday and Friday, you plan weight training workouts. On Tuesday and Thursday, plan 20 to 30 minutes of aerobic exercise, such as cycling, running or swimming. Rest from both weight training and aerobic exercise for at least one full day each week to give your body time to regenerate. By combining weight training with aerobic exercise, you can reshape and strengthen your body, plus develop a stronger heart and lungs.

PERSONALIZING YOUR EXERCISE PROGRAM

We have not specified an exact length of time for each workout, or a specific number of repetitions or sets for each exercise. It is very important to avoid overdoing it during the first few months of your exercise program, and to progress at your own pace. If you experience pain or dizziness at any time while exercising, stop immediately and begin to cool down. Find out what is wrong before continuing. Remember that adequate rest and a proper diet are also important.

WARMING UP

Begin each workout with 5 to 10 minutes of light stretching and exercise to warm up. Warming up prepares your body for exercise by increasing circulation, raising your body temperature and delivering more oxygen to your muscles.

WORKING OUT

Each workout should include 6 to 10 different exercises. Select exercises for every major muscle group, with emphasis on the areas that you want to develop the most. To give balance and variety to your workouts, vary the exercises from workout to workout.

Schedule your workouts for the time of day when your energy level is the highest. Each workout should be followed by at least one day of rest. Once you find the schedule that is right for you, stick with it.

EXERCISE FORM

In order to obtain the greatest benefits from exercising, it is essential to maintain proper form.

Maintaining proper form means moving through the full range of motion for each exercise, and moving only the appropriate parts of the body. Exercising in an uncontrolled manner will leave you feeling exhausted. On the exercise poster accompanying this manual, you will find photographs showing the correct form for several exercises. A description of each exercise is also provided, along with a list of the muscles affected. Refer to the muscle chart on page 12 to find the locations of the muscles.

The repetitions in each set should be performed smoothly and without pausing. The exertion stage of each repetition should last about half as long as the return stage. Proper breathing is important. Exhale during the exertion stage of each repetition and inhale during the return stroke; never hold your breath. Rest

for 3 minutes after each set if you are doing a muscle building workout, 1 minute after each set if you are doing a toning workout, and 30 seconds after each set if you are doing a weight loss workout. Plan to spend the first couple of weeks familiarizing yourself with the equipment and learning the proper form for each exercise.

COOLING DOWN

End each workout with 5 to 10 minutes of stretching. Include stretches for both your arms and legs. Move slowly as you stretch—do not bounce. Ease into each stretch gradually and go only as far as you can without strain. Stretching at the end of each workout is very effective for increasing flexibility.

STAYING MOTIVATED

For motivation, keep a record of each workout. The charts on page 13 of this manual can be photocopied and used to schedule and record your workouts. List the date, exercises performed, weight, and numbers of sets and repetitions completed. Record your weight and key body measurements at the end of every month.

Remember, the key to achieving the greatest results is to make exercise a regular and enjoyable part of your everyday life.

MUSCLE CHART

- A. Sternomastoid (neck)
- B. Pectoralis Major (chest)
- C. Biceps (front of arm)
- D. Obliques (waist)
- E. Brachioradials (forearm)
- F. Hip Flexors (upper thigh)
- G. Abductor (outer thigh)
- H. Quadriceps (front of thigh)
- I. Sartorius (front of thigh)
- J. Tibialis Anterior (front of calf)
- K. Soleus (front of calf)
- L. Rectus Abdominus (stomach)
- M. Adductor (inner thigh)
- N. Trapezius (upper back)
- O. Rhomboideus (upper back)
- P. Deltoid (shoulder)
- Q. Triceps (back of arm)
- R. Latissimus Dorsi (mid back)
- S. Spinae Erectors (lower back)
- T. Gluteus Medius (hip)
- U. Gluteus Maximus (buttocks)
- V. Hamstring (back of leg)
- W. Gastrocnemius (back of calf)

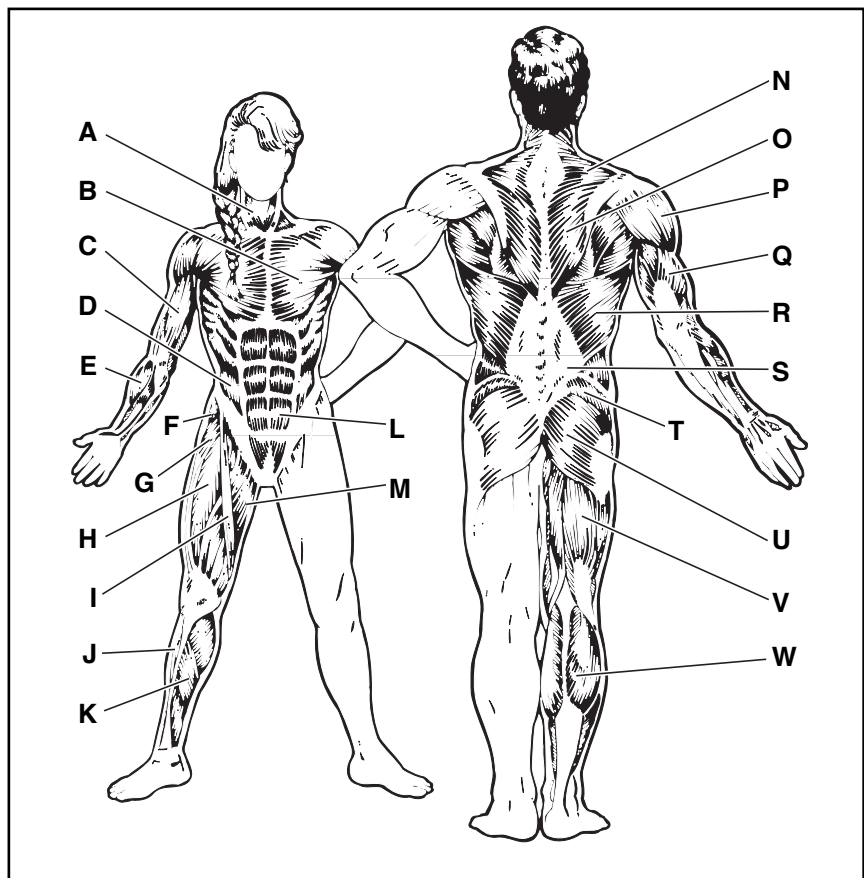

MONDAY	EXERCISE	WEIGHT	SETS	REPS
Date: / /				

TUESDAY AEROBIC EXERCISE

Date: / /

WEDNESDAY	EXERCISE	WEIGHT	SETS	REPS
Date: / /				

THURSDAY AEROBIC EXERCISE

Date: / /

FRIDAY	EXERCISE	WEIGHT	SETS	REPS
Date: / /				

Make photocopies of this page for scheduling and recording your workouts.

Part List—Model No. WEBE13100

R0800A

Key No.	Qty.	Description	Key No.	Qty.	Description
1	2	Upright	24	4	M10 Washer
2	1	Frame	25	4	M6 Washer
3	1	Crossbar	26	1	Curl Post
4	1	Leg Lever	27	1	Curl Pad
5	1	Right Backrest Tube	28	2	Carriage Bushing
6	1	Backrest	29	1	1" Angle Cap
7	2	Upright Base	30	2	M10 x 67mm Adjustment Knob
8	1	Front Leg	31	2	60mm x 50mm Bushing
9	6	3/4" Round Inner Cap	32	1	Adjustment Pin
10	3	Pad Tube	33	1	M10 x 48mm Adjustment Knob
11	1	Seat	34	4	M4 x 16mm Screw
12	4	1" Square Inner Cap	35	10	M10 x 81mm Bolt
13	1	M8 Nylon Locknut	36	2	1" x 2" Inner Cap
14	1	"U" Bracket	37	1	Spacer
15	6	M6 x 16mm Screw	38	2	M8 Washer
16	4	M6 x 38mm Screw	39	1	M8 x 58mm Bolt
17	1	M10 x 178mm Bolt	40	1	M10 x 72mm Bolt
18	2	M10 x 65mm Bolt	41	1	Weight Tube
19	14	M10 Nylon Locknut	42	1	Left Backrest Tube
20	4	Support Plate	43	1	Pin Clip
21	4	45mm Square Inner Cap	#	1	User's Manual
22	6	Foam Pad	#	1	Exercise Poster
23	1	1" Round Inner Cap			

"#" Indicates a non-illustrated part. Specifications are subject to change without notice. See the back cover for information on ordering replacement parts.

Exploded Drawing—Model No. WEBE13100

R0800A

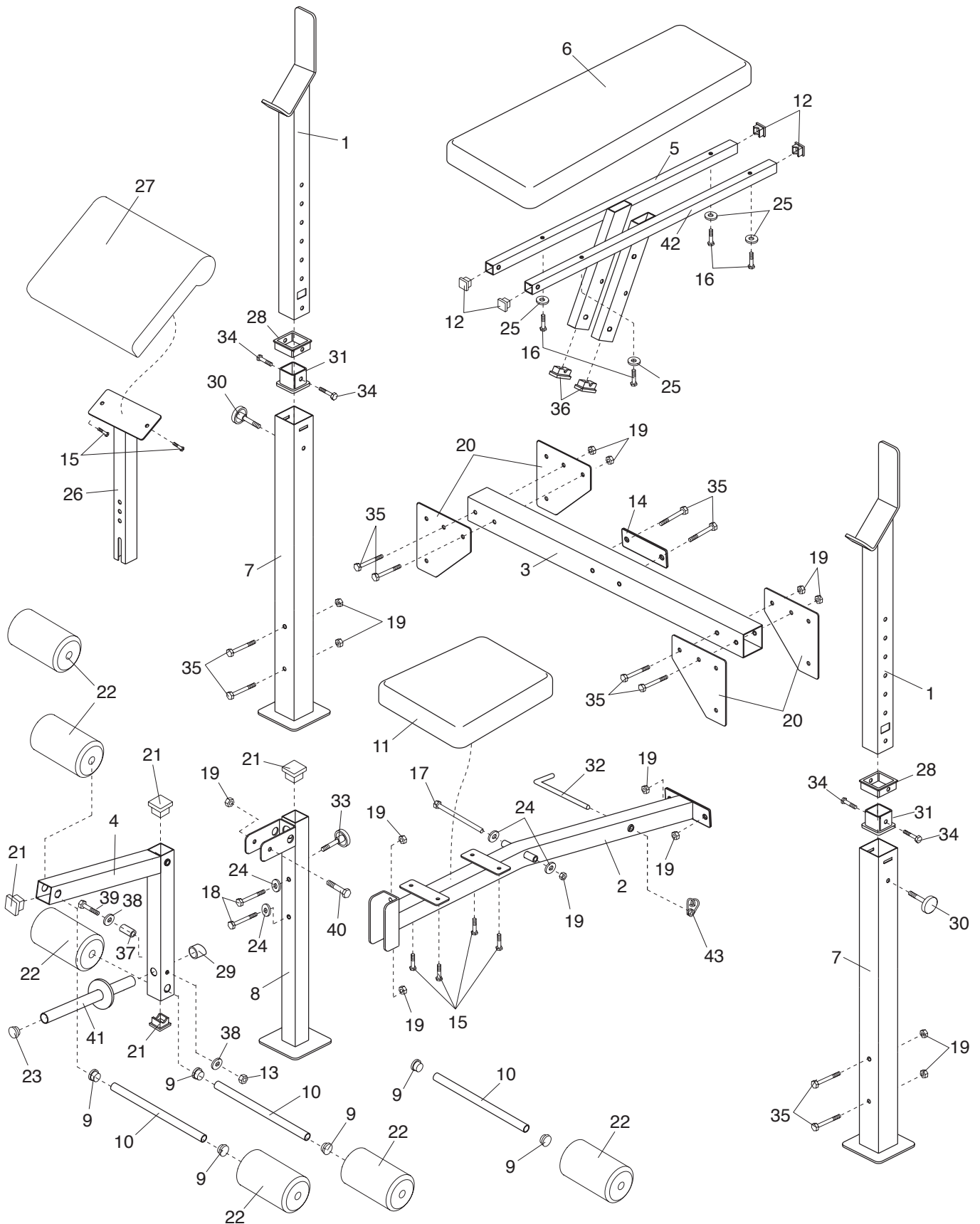

Ordering Replacement Parts

To order replacement parts, simply call our Customer Service Department toll-free at 1-800-999-3756, Monday through Friday, 6 a.m. until 6 p.m. Mountain Time (excluding holidays). To help us assist you, please be prepared to give the following information when calling:

1. The MODEL NUMBER of the product (WEBE13100)
2. The NAME of the product (WEIDER® PRO 455 weight bench)
3. The SERIAL NUMBER of the product (see the front cover of this manual)
4. The KEY NUMBER and DESCRIPTION of the desired part(s) (see the PART LIST and the EXPLODED DRAWING on pages 14 and 15).

Limited Warranty

ICON Health & Fitness, Inc. (ICON), warrants this product to be free from defects in workmanship and material, under normal use and service conditions, for a period of ninety (90) days from the date of purchase. This warranty extends only to the original purchaser. ICON's obligation under this warranty is limited to replacing or repairing, at ICON's option, the product at one of its authorized service centers. All products for which warranty claim is made must be received by ICON at one of its authorized service centers with all freight and other transportation charges prepaid, accompanied by sufficient proof of purchase. All returns must be pre-authorized by ICON. This warranty does not extend to any product or damage to a product caused by or attributable to freight damage, abuse, misuse, improper or abnormal usage or repairs not provided by an ICON authorized service center, products used for commercial or rental purposes, or products used as store display models. No other warranty beyond that specifically set forth above is authorized by ICON.

ICON is not responsible or liable for indirect, special or consequential damages arising out of or in connection with the use or performance of the product or damages with respect to any economic loss, loss of property, loss of revenues or profits, loss of enjoyment or use, costs of removal, installation or other consequential damages of whatsoever nature. Some states do not allow the exclusion or limitation of incidental or consequential damages. Accordingly, the above limitation may not apply to you.

The warranty extended hereunder is in lieu of any and all other warranties and any implied warranties of merchantability or fitness for a particular purpose is limited in its scope and duration to the terms set forth herein. Some states do not allow limitations on how long an implied warranty lasts. Accordingly, the above limitation may not apply to you.

This warranty gives you specific legal rights. You may also have other rights which vary from state to state.

ICON HEALTH & FITNESS, INC., 1500 S. 1000 W., LOGAN, UT 84321-9813